

# MForce

## Motion Control stepper motor drive, RS-422/485 programmable

### Product overview

MForce products are universally applicable stepper motor drives with on-board programmable motion controller. Reference values are set via serial RS-422/485 communications. Together with selected Schneider Electric Motion USA stepper motors, MForce is a very compact, high performance drive system that can be used without a PLC.

MForce operating voltage ranges are:

- 12 to 48 VDC — MForce MicroDrive
- 12 to 75 VDC — MForce PowerDrive



MForce MicroDrive (above left) and PowerDrive (above right) programmable motion control via serial RS-422/485

### Connection technologies

Motion Control MForce connections include:

- Power input
- Communication interface
- Motor interface
- Multifunction interface

The multifunction interface operates at the following signal levels:

- 5 - 24 V programmable signals, inputs or outputs, sinking or sourcing

Up to eight 24 V I/O signals are available via the multifunction interface, which can be configured as sinking or sourcing inputs or outputs. They can be used for the following predefined functions:

Input functions: home, limit +, limit -, go, stop, pause, jog +, jog -, general purpose.

Output functions: moving, error, stall, velocity changing, general purpose.

- Analog input signal  
The one input signal accepts interface to a range of input types in voltage or current mode. In voltage mode it will accept input from 0 to 5 V or 0 to 10 V devices. In current mode it will accept input from 4 to 20 mA or 0 to 20 mA devices.

- 0 - 5 V capture input or trip output signal  
The one capture/trip I/O high speed signal can be used to capture the axis position when active, or to control an external event when configured as a trip output.
- 0 - 5 V pulse/direction output signals  
Two pulse/direction I/O signals can be used to control a secondary device with pulse/direction inputs in an electronic gearing application. When configured as inputs they can be used to receive pulse/direction signals from a master controller.

### Communication interface

The communication interface is used to connect RS-422/485 for setup and programming purposes. A PC can be connected to the communication interface via a USB to RS-422/485 converter. The provided software can be used for commissioning functionality, creating programs and programming the MForce drives.



Official UK & Ireland Distributor

# MForce

## Motion Control stepper motor drive, RS-422/485 programmable

### Electrical data

Power supply connection (1)

		MForce MicroDrive	MForce PowerDrive
Supply voltage range (absolute limit values)	VDC	12 ... 48	12 ... 75
Nominal supply voltage	VDC	24 ... 48	24 ... 48
Ripple at nominal voltage	V <sub>PP</sub>	2	2
Motor drive output current	A rms	3.0	5.0
Max. current consumption	A	4.2	7.0
Inrush current		C=94 µF	C=200 µF

(1) Not protected against reverse polarity

### General purpose I/O

Number/Type		Standard features: 4 sinking outputs / 4 sourcing or sinking inputs	Expanded features: 8 sourcing or sinking outputs/ inputs (or 4 with remote encoder interface option)	8 sourcing or sinking outputs/inputs (or 4 with remote encoder interface option)
When defined as inputs	VDC	0 to +24		
	Input current (typical at +24VDC)	mA 1.75 maximum		
When defined as outputs	VDC	Up to +24		
	Sourcing/sinking output current	mA 600 (single channel, duty cycle = 0.80)		

### Communication interface

RS-422/485	Signal inputs/outputs	According to RS-422/485, no galvanic isolation, 2-wire
	Transmission rate	kBaud 4.8 / 9.6 / 19.2 / 38.4 / 115
	Transmission protocol	Manufacturer-specific

### Mechanical data

Dimensions (W x H x D)	inch	1.8 x 1.3 x 2.3	3.0 x 2.1 x 3.9
	mm	45 x 33 x 59	76 x 54 x 99
Mass	oz	3	12
	kg	0.08	0.34
Type of cooling		Convection and conduction	Convection

### Ambient conditions

Ambient temperature (2)	°C	0 ... 65; power reduction by 2%/°C at 50 ... 65
Transport and storage temperature	°C	-25 ... +70
Installation height without power reduction	m	< 1000 m above mean sea level
Relative humidity	%	15 ... 85 (not condensing)

(2) Limit values with flanged motor mounted on a steel plate 300 x 300 x 10 mm

### Certifications

Conformity to standards		MForce drives have been developed to conform to the requirements of EN 55011:2007, A2:2007 for Group 1, Class A, conducted and radiated emissions EN 61000-3-2:2006 harmonic current emissions EN 61000-3-3:1995, A1:2001, A2:2005 voltage fluctuation emissions. (Proper use of power supply/mains filters and shielding on power and interface cables is necessary to meet these requirements.)
EMC immunity		IEC 61000-4-2, electrostatic discharge immunity IEC 61000-4-3, radiated electromagnetic field immunity IEC 61000-4-4, electrical fast transient / burst immunity IEC 61000-4-5, surge immunity IEC 61000-4-6, immunity to conducted disturbances induced by RF fields IEC 61000-4-11, immunity to voltage dips and interruptions
Conducted and radiated EMC emissions		EN 55011:2007, A2:2007 for Group 1, Class A
CE marking		The MForce drives are CE marked in accordance with the European EMC Directive (2004/108/EEC).

# MForce

## Motion Control stepper motor drive, RS-422/485 programmable

### Dimensions

#### MForce MicroDrive

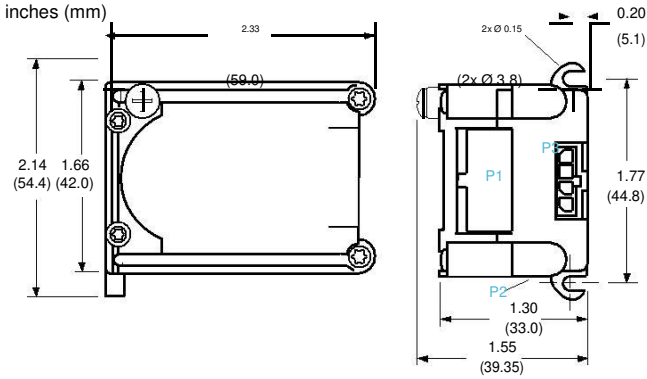

#### P1 connector options

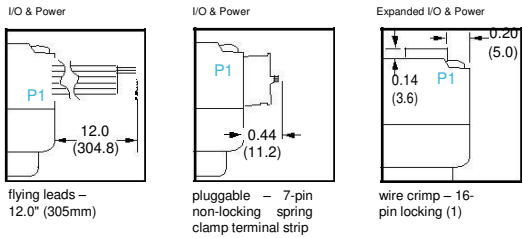

(1) 16-pin locking wire crimp connector at P1 only on products with expanded features.

#### P2 connector options

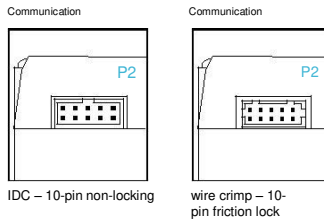

#### P3 connector

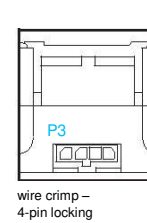

#### MForce PowerDrive

inches (mm)

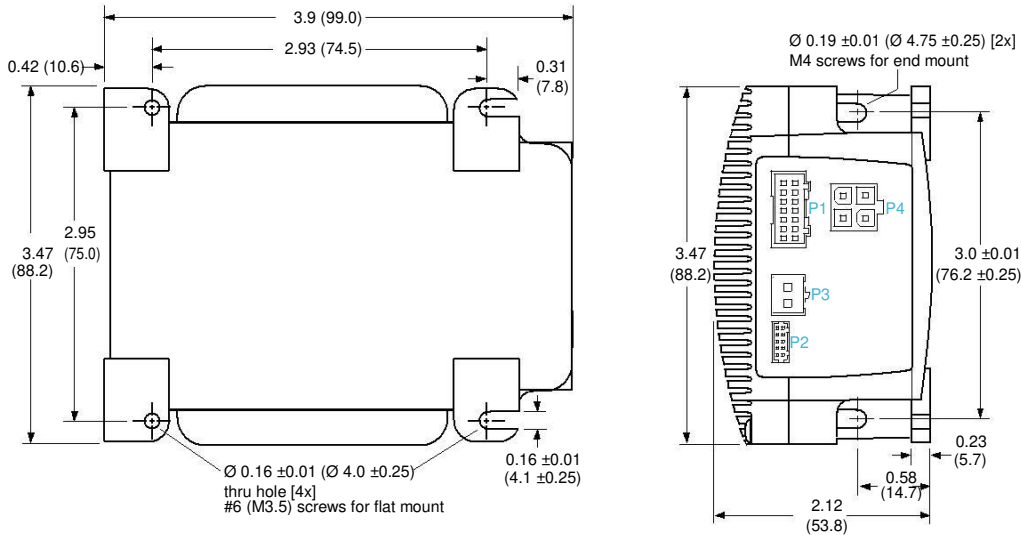

#### P1 connector

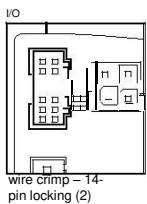

#### P2 connector

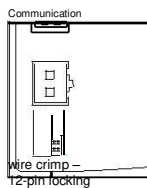

#### P3 connector

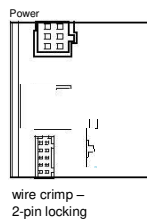

#### P4 connector

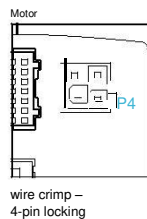

(2) Products with optional remote encoder interface have a 20-pin connector at P1.

# MForce

## Motion Control stepper motor drive, RS-422/485 programmable

### Connectivity

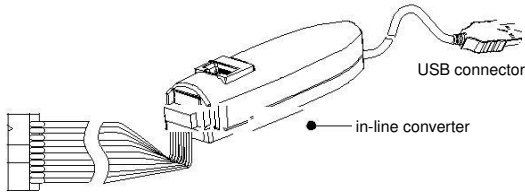

10-pin connector

MD-CC400-001

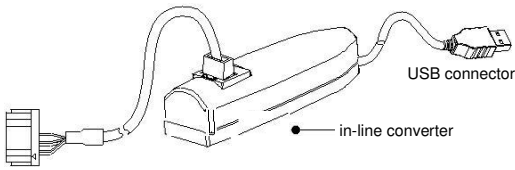

10-pin connector

MD-CC402-001

#### MicroDrive



Connector	Style	Assignment
P1	7-pin terminal strip, 12" flying leads or 16-pin wire crimp	Power and multifunction
P2	10-pin wire crimp or 10-pin IDC	Communication
P3	4-pin wire crimp	Motor

#### PowerDrive



Connector	Style	Assignment
P1	14- or 20-pin wire crimp	Multifunction
P2	10-pin wire crimp	Communication
P3	2-pin wire crimp	Power
P4	4-pin wire crimp	Motor

#### Communication converter

Electrically isolated, in-line converter pre-wired with mating connector to conveniently set/program communication parameters for a single MForce via a PC's USB port.

length  
feet (m)    part number

Mates to 10-pin non-locking IDC connector	12.0 (3.6)	MD-CC400-001
Mates to 10-pin wire crimp connector	12.0 (3.6)	MD-CC402-001

#### Cables

To speed your test/development, these cables are pre-wired with mating connectors.

length  
feet (m)    part number

#### MicroDrive

P1 mate	Power and multifunction interface	10.0 (3.0)	PD16-1417-FL3
P2 mate	Communication interface	10.0 (3.0)	PD10-1434-FL3
P3 mate	Motor interface	10.0 (3.0)	PD04-MF17-FL3

#### PowerDrive

P1 mate	Multifunction interface	14-pin wire crimp	10.0 (3.0)	PD14-2334-FL3
		20-pin wire crimp	10.0 (3.0)	PD20-3400-FL3
P2 mate	Communication interface		10.0 (3.0)	PD10-1434-FL3
P3 mate	Power interface		10.0 (3.0)	PD02-3400-FL3
P4 mate	Motor interface		10.0 (3.0)	PD04-MF34-FL3

#### Connector kits

Connectors for assembly of cables. Cable not supplied.

Sold in  
lots of    part number

#### MicroDrive

P1 mate	Power and multifunction interface		5	CK-10
P2 mate	Communication interface	10-pin wire crimp	5	CK-02
		10-pin IDC	5	CK-01
P3 mate	Motor interface		5	CK-06

#### PowerDrive

P1 mate	Multifunction interface	14-pin	5	CK-09
		20-pin	5	CK-11
P2 mate	Communication interface		5	CK-02
P3 mate	Power interface		5	CK-05
P4 mate	Motor interface		5	CK-07

# MForce

## Motion Control stepper motor drive, RS-422/485 programmable



MForce MicroDrive stepper motor drive programmable motion control for serial RS-422/485

### Part numbers

#### MicroDrive

example part number	M F I 1 F R D 1 7 N 4
Product designation MFI = Programmable Motion Control via serial RS-422/485	M F I 1 F R D 1 7 N 4
Input 1 = standard features 3 = expanded features (1)	M F I 1 F R D 1 7 N 4
P1 connector style F = flying leads P = terminal strip C = wire crimp (1)	M F I 1 F R D 1 7 N 4
P2 connector style RD = IDC RL = wire crimp	M F I 1 F R D 1 7 N 4
MForce version 17 = MicroDrive	M F I 1 F R D 1 7 N 4
Supply voltage N4 = 48 VDC	M F I 1 F R D 1 7 N 4
Option (1) -EE = Interface for a remote encoder (not supplied)	M F I 1 F R D 1 7 N 4 -EE

(1) Only available on products with expanded features.

#### PowerDrive

example part number	M F I 3 C R L 3 4 N 7
Product designation MFI = Programmable Motion Control via serial RS-422/485	M F I 3 C R L 3 4 N 7
Interface 1CRL = standard connector interface	M F I 3 C R L 3 4 N 7
MForce version 34 = PowerDrive	M F I 3 C R L 3 4 N 7
Supply voltage N7 = 75 VDC	M F I 3 C R L 3 4 N 7
Option -EE = Interface for a remote encoder (not supplied)	M F I 3 C R L 3 4 N 7 -EE



MForce PowerDrive stepper motor drive programmable motion control for serial RS-422/485

# MForce

## Motion Control stepper motor drive, RS-422/485 programmable

### Optional motors

#### 2-phase stepper motors

Full steps per revolution	200
Step angle $\alpha$	1.8 °
Number of leads	4
Ambient temperature	-25 ... +40 °C
Thermal class	130 (B)

#### Electrical and mechanical data

NEMA14	M-1410-0.75• (1)																	
Stack length	single																	
Phase current	amps	0.75																
Holding torque	oz-in / N-cm	10 / 7																
Rotor inertia	oz-in-sec <sup>2</sup>	0.00017																
	kg-cm <sup>2</sup>	0.012																
Phase inductance	mH	4.0																
Phase resistance	Ω	4.3																
Weight	oz / grams	4.2 / 120																
NEMA17	M-1713-1.5• (1)			M-1715-1.5• (1)			M-1719-1.5• (1)											
Stack length	single	double	triple															
Phase current	amps	1.5	1.5	1.5														
Holding torque	oz-in / N-cm	32 / 23	60 / 42	75 / 53														
Rotor inertia	oz-in-sec <sup>2</sup>	0.000538	0.0008037	0.0011562														
	kg-cm <sup>2</sup>	0.038	0.057	0.082														
Phase inductance	mH	2.1	5.0	3.85														
Phase resistance	Ω	1.3	2.1	2.0														
Weight	oz / grams	7.4 / 210	8.1 / 230	12.7 / 360														
NEMA23	M-2218-2.4S (2)		M-2222-2.4S (2)		M-2231-2.4S (2)		M-2218-3.0• (2)		M-2222-3.0• (2)		M-2231-3.0• (2)		M-2218-6.0• (3)		M-2222-6.0• (3)		M-2231-6.0• (3)	
Stack length	single	double	triple	single	double	triple	single	double	triple	single	double	triple	single	double	triple			
Phase current	amps	2.4	2.4	2.4	3.0	3.0	3.0	6.0	6.0	6.0	6.0	6.0	6.0	6.0	6.0			
Holding torque	oz-in / N-cm	90 / 64	144 / 102	239 / 169	90 / 64	144 / 102	239 / 169	100 / 71	150 / 106	257 / 181								
Rotor inertia	oz-in-sec <sup>2</sup>	0.00255	0.00368	0.0065	0.00255	0.00368	0.0065	0.0017	0.00397	0.0068								
	kg-cm <sup>2</sup>	0.18	0.26	0.46	0.18	0.26	0.46	0.12	0.28	0.48								
Phase inductance	mH	2.4	4.0	5.4	1.5	2.6	3.36	0.47	0.73	1.04								
Phase resistance	Ω	0.95	1.2	1.5	0.65	0.85	0.95	0.16	0.19	0.23								
Weight	oz / grams	16.9 / 480	21.2 / 600	35.3 / 1000	16.9 / 480	21.2 / 600	35.3 / 1000	16.6 / 470	24.7 / 700	35.3 / 1000								
NEMA34	M-3424-6.3• (3)			M-3431-6.3• (3)			M-3447-6.3• (3)											
Stack length	single	double	triple															
Phase current	amps	6.3	6.3	6.3														
Holding torque	oz-in / N-cm	408 / 288	574 / 405	1090 / 770														
Rotor inertia	oz-in-sec <sup>2</sup>	0.01275	0.01924	0.03849														
	kg-cm <sup>2</sup>	0.90	1.35	2.70														
Phase inductance	mH	1.9	3.3	6.2														
Phase resistance	Ω	0.30	0.32	0.56														
Weight	oz / grams	60.0 / 1700	84.7 / 2400	141.1 / 4000														

(1) Recommended for use with MForce MicroDrives.

(2) Recommended for use with MForce MicroDrives and PowerDrives.

(3) Recommended for use with MForce PowerDrives.

Schneider Electric Motion USA  
370 North Main Street  
Marlborough, CT 06447  
www.motion.schneider-electric.com

UK & Ireland Distributor: Motion Control Products Ltd.  
11-15 Francis Avenue, Bournemouth, Dorset, UK BH11 8NX  
Tel.: +44 (0)1202 599922 Fax: +44 (0)1202 599955 [www.motioncontrolproducts.com](http://www.motioncontrolproducts.com)